

Not for sale
売り物ではない



option



option

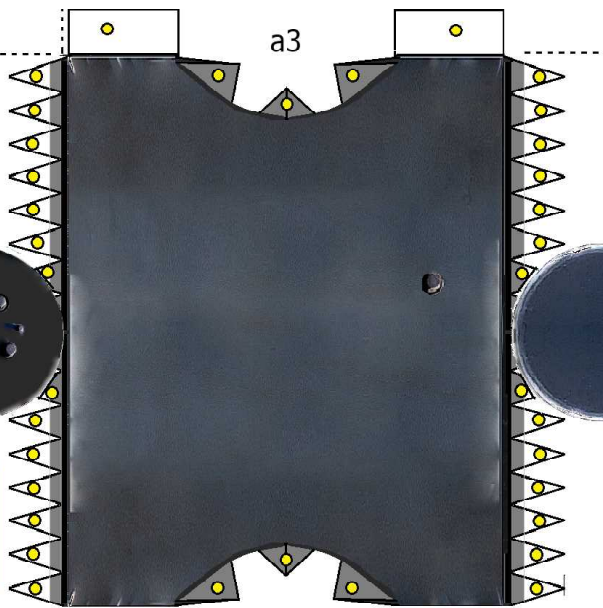
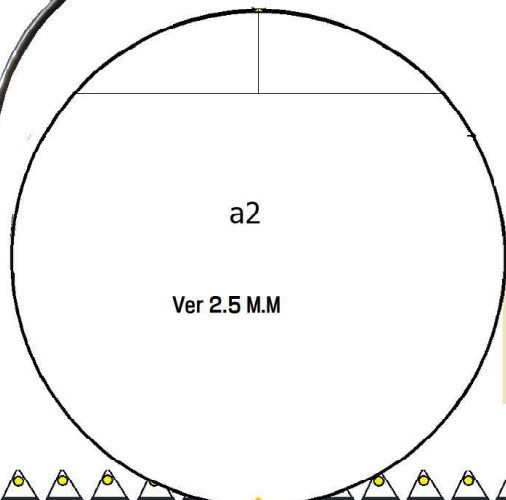

a5-4 (1/6)

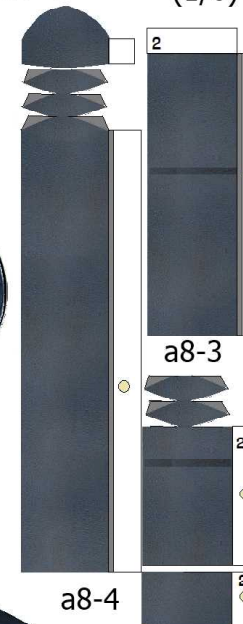

a8-3



option

a8-4



a8-5



a8-6

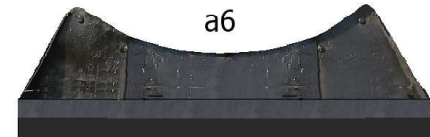
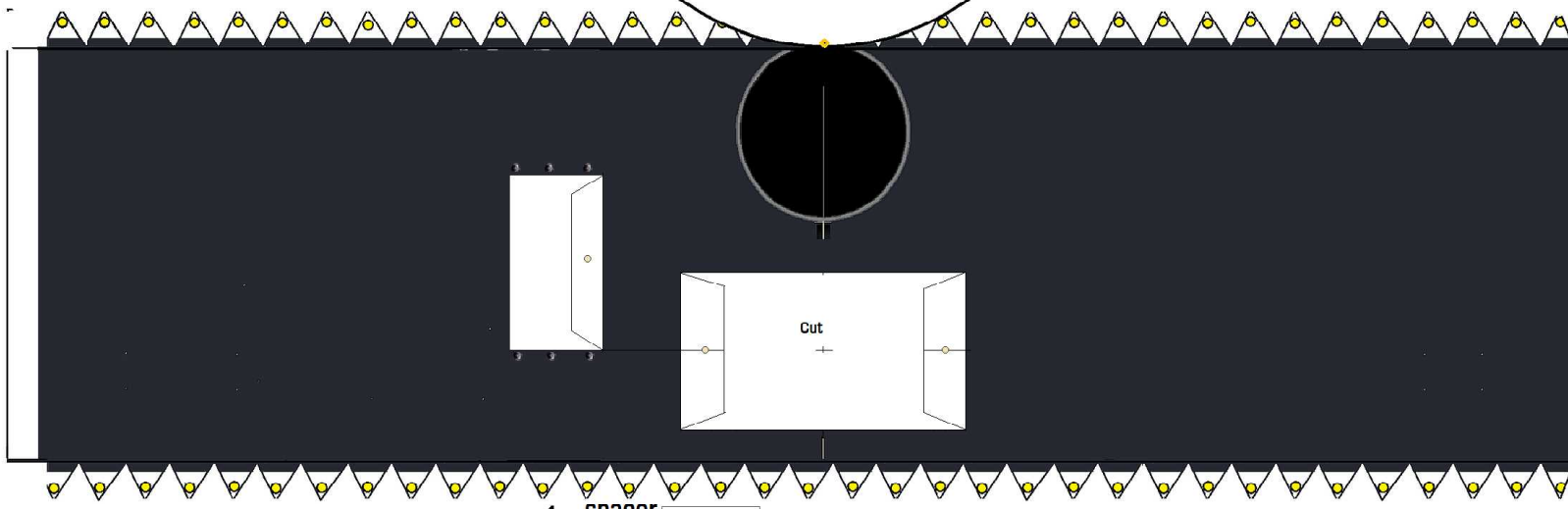
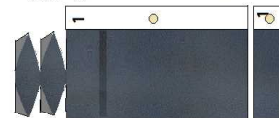

a4 spacer

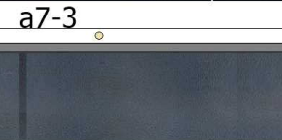
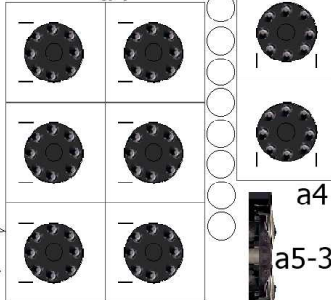

option



a8-1

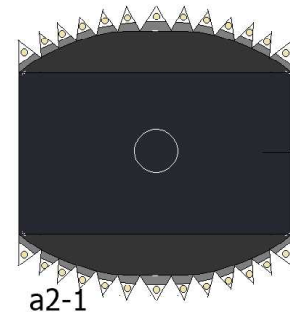
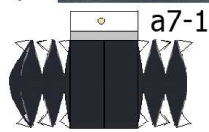

a2-1

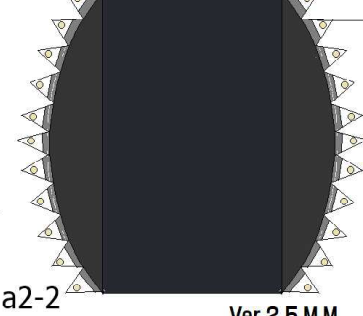

a2-2

Ver 2.5 M.M

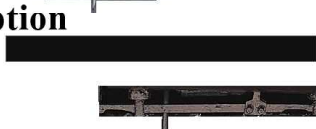
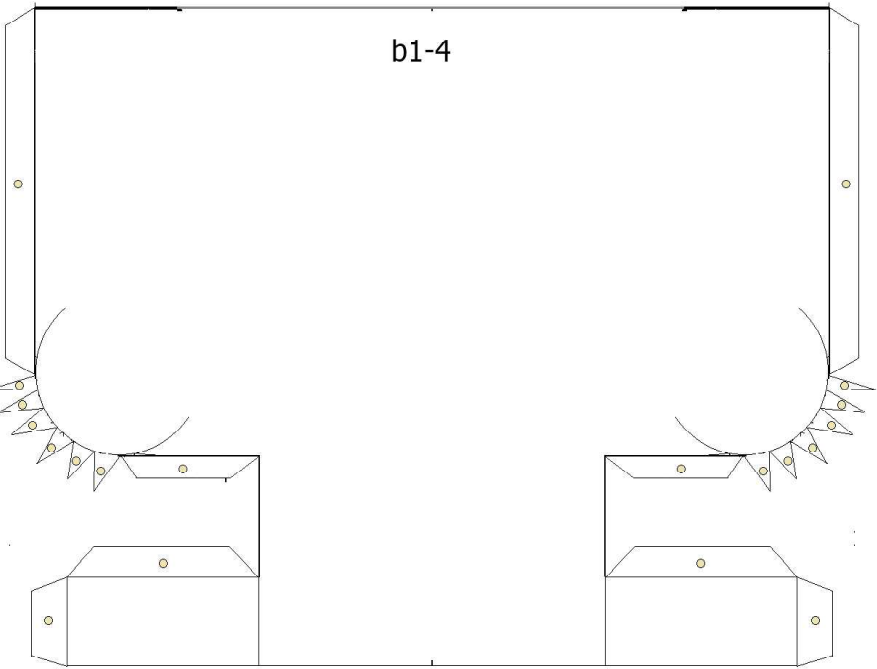
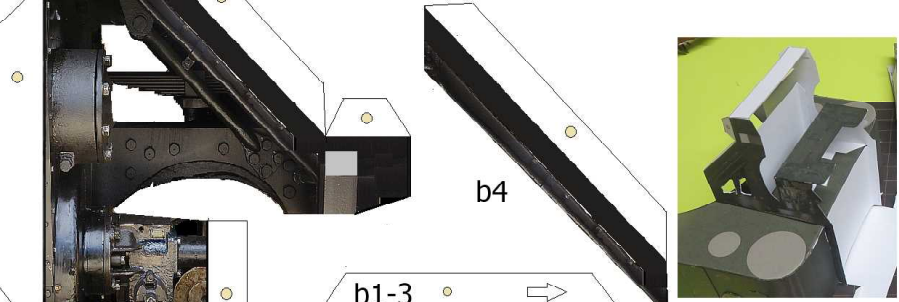
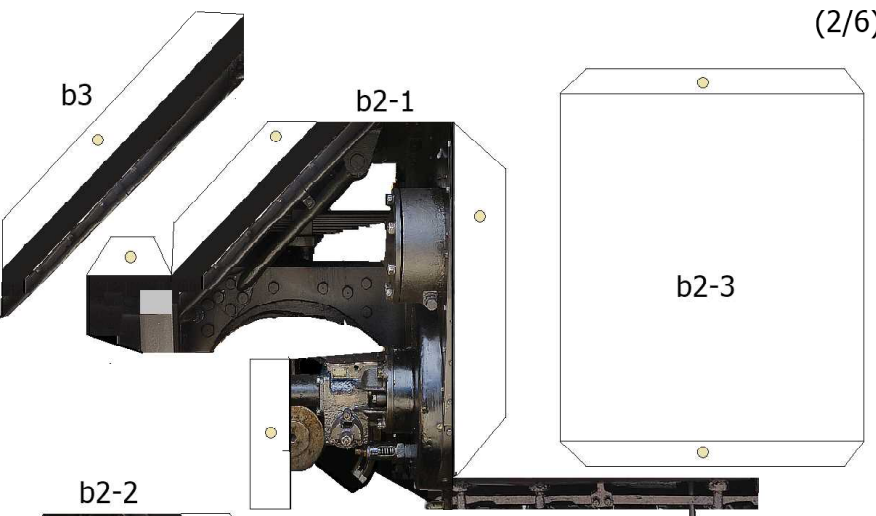
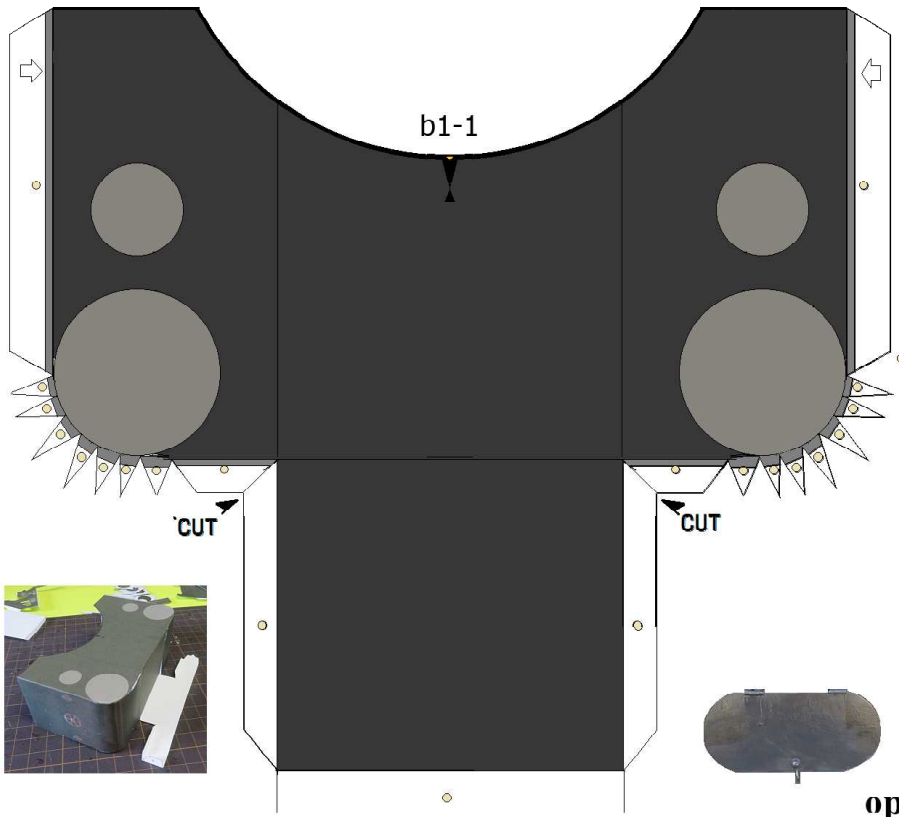

option

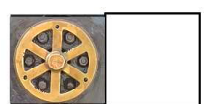
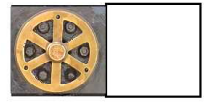
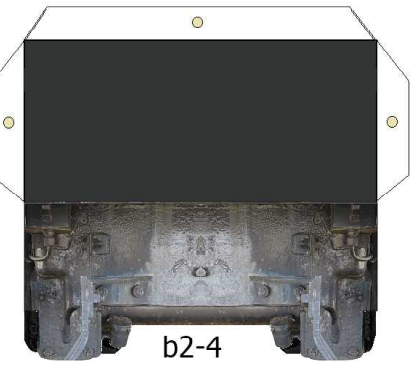

option



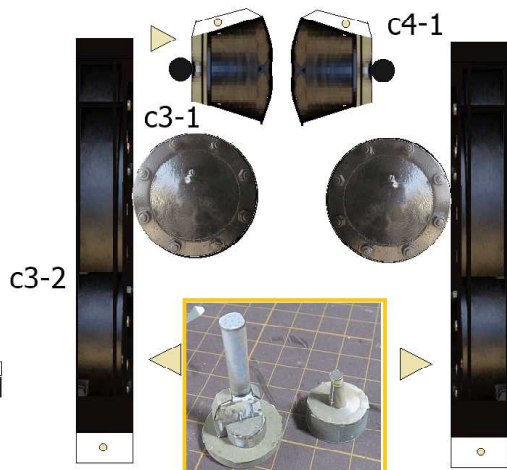
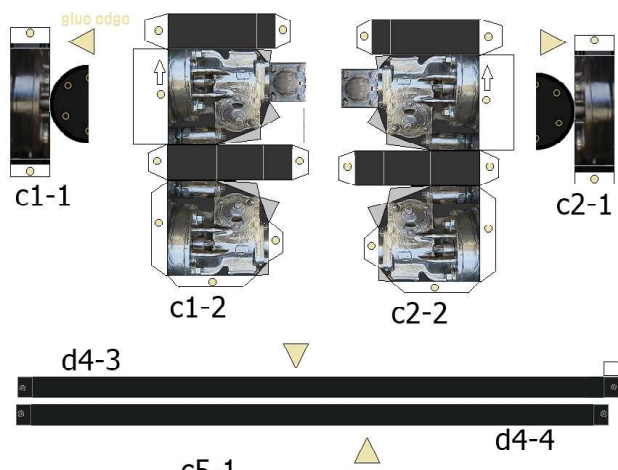

のりしろのない部分は
エッジ(断面)にボンド

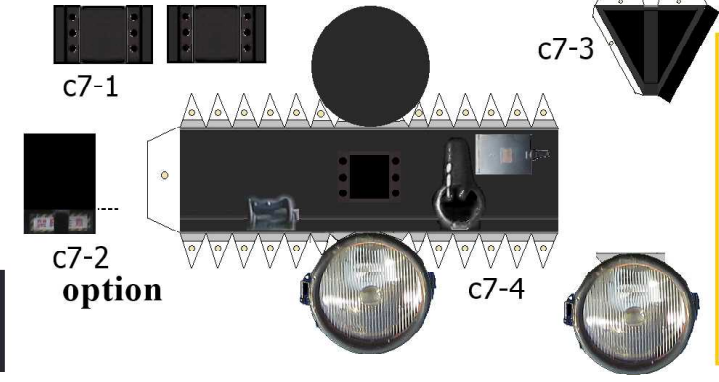
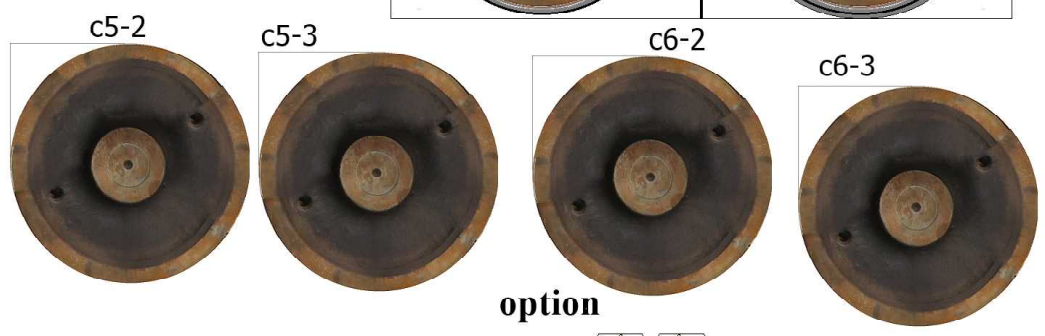
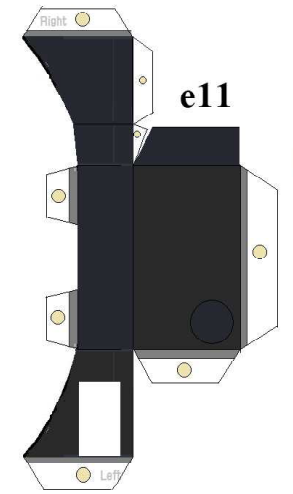
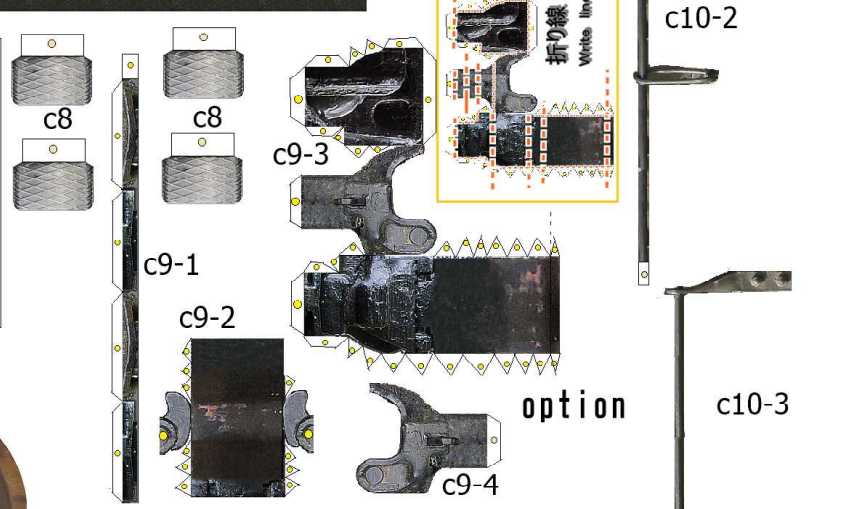
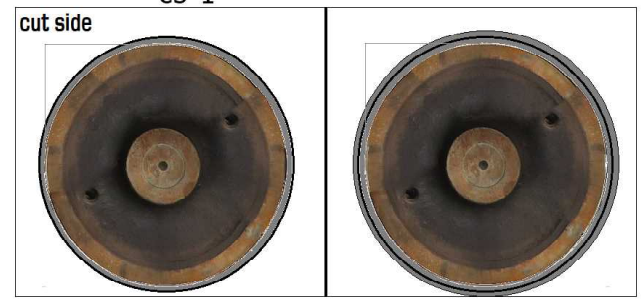
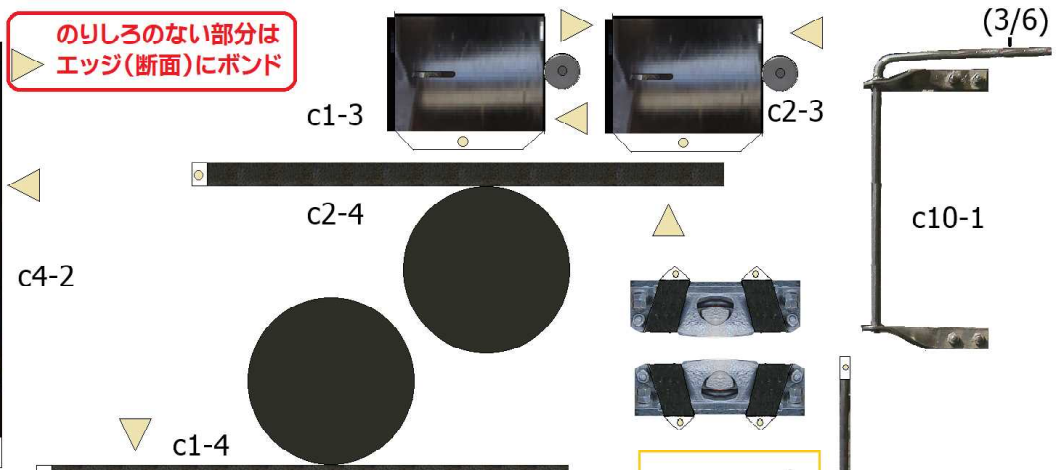

ア-14-3576・147654-VI-V



提供：観光ボランティア「おいでませ山口桜NAVI

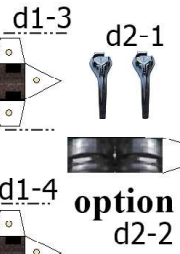
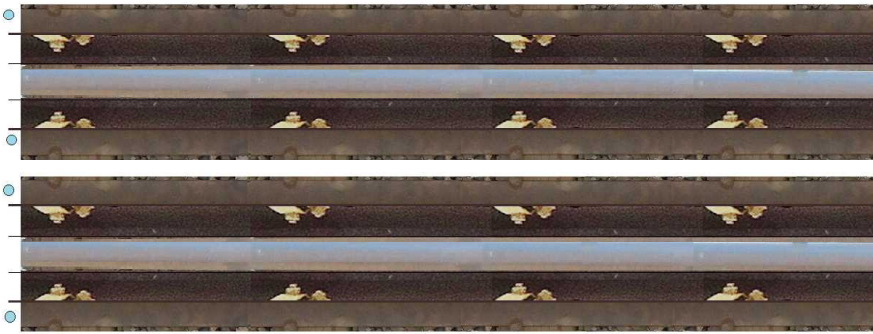

option

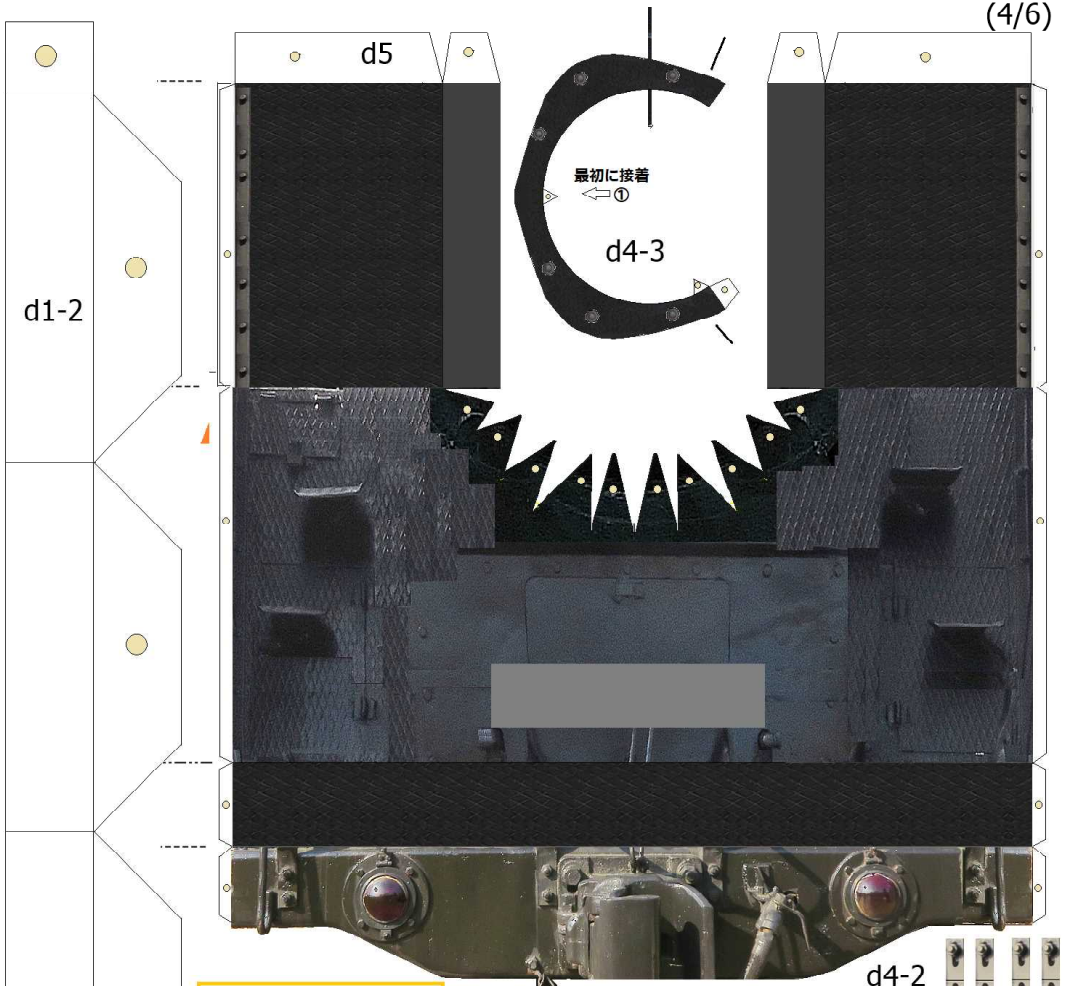
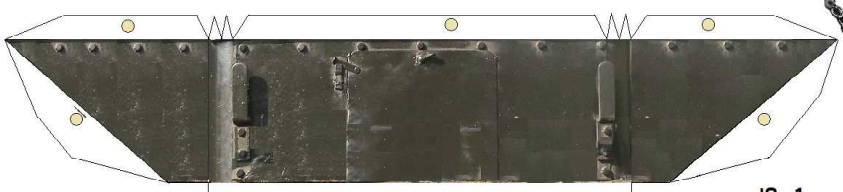

最初に接着

d4-3

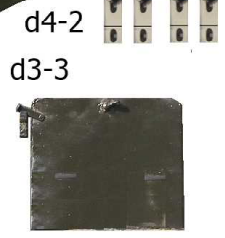

Not for sale
売り物ではない

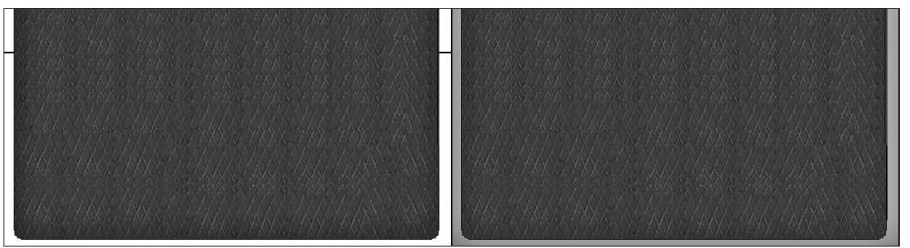

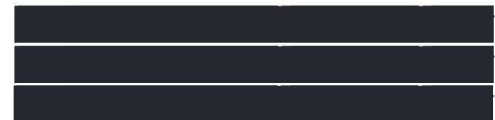
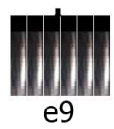
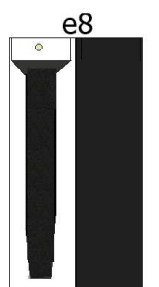
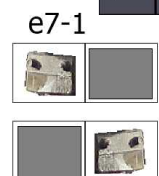
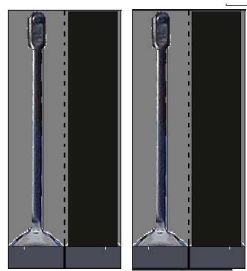
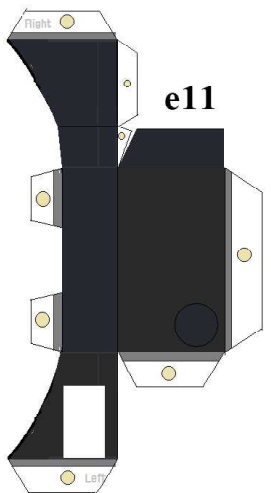
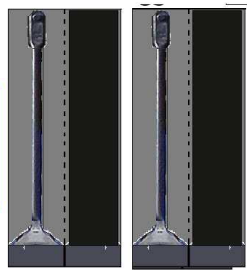
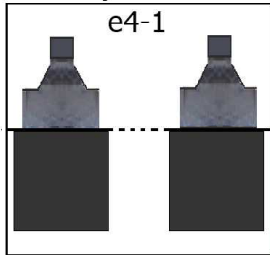
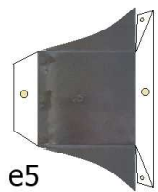
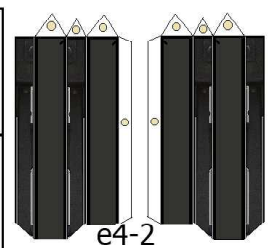
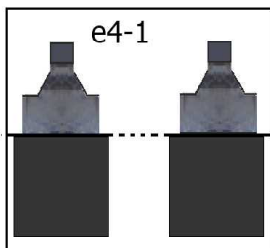
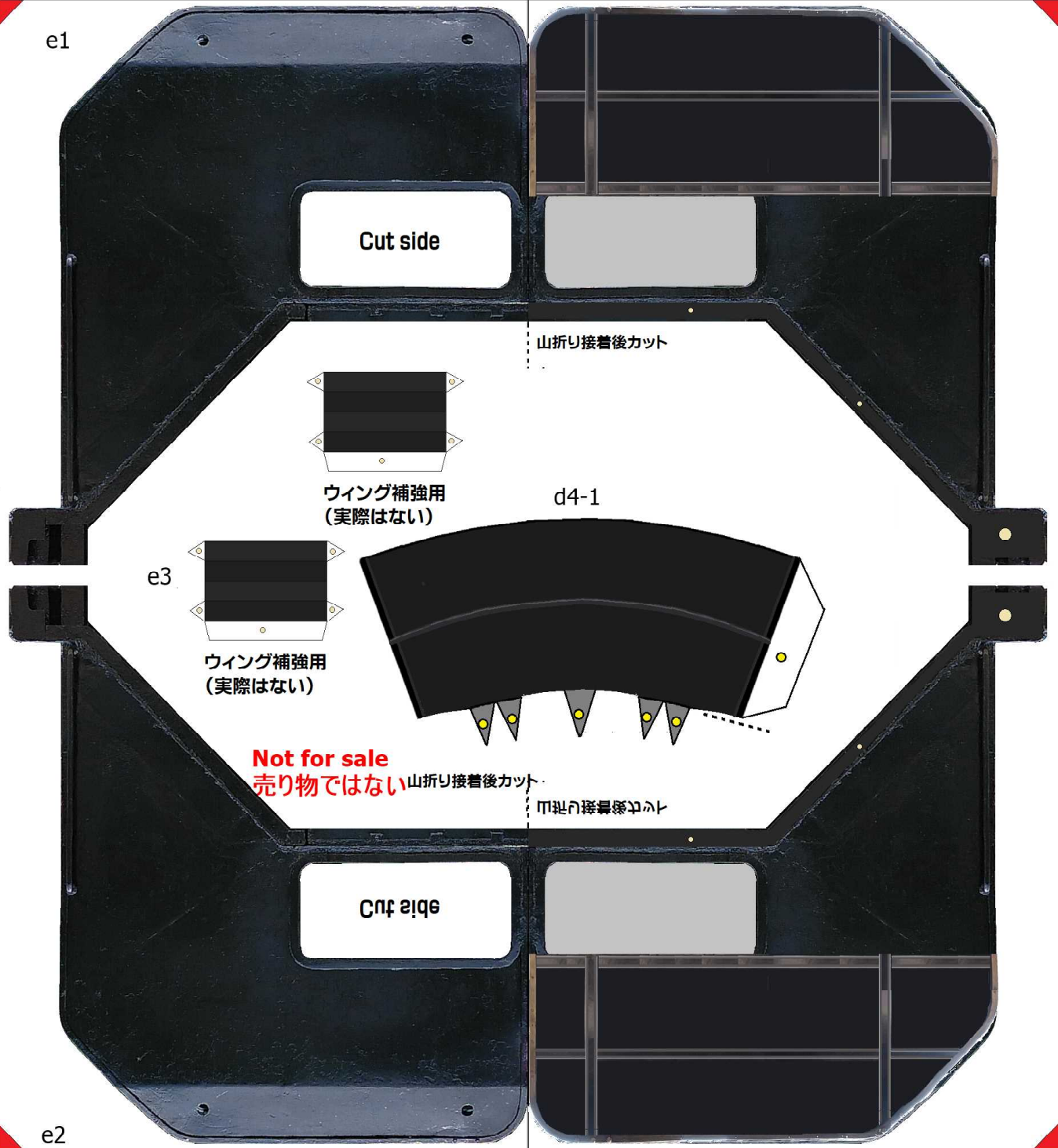

f1

f2

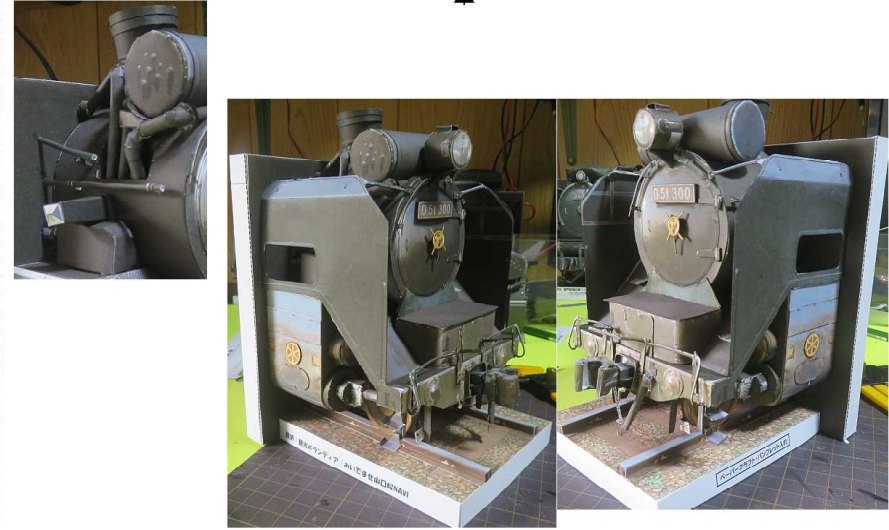

このデゴイチは、昭和14年10月に川崎車両KKで誕生しました。東北地方で活躍していましたが昭和33年10月に厚狭機関区に配属となり美祿線の石灰輸送を最後に昭和47年12月1日で廃車となりました。この間の走行距離は186万2426.2kmで、地球を約46.5回廻ったことになります。

戦前、戦後を通じ、輸送の原動力として日本経済の発展に活躍したD51300号の雄姿を永く保存し、青少年の教育に役立てるため日本国有鉄道から昭和48年に借受け、殿町児童公園に展示することになりました。

諸元表

長さ 19,500mm 重量123t
幅 2,934mm
高さ 3,980mm 馬力 1,308HP
新製 昭和14年10月31日
価格 3,334万1,873円(財産額)

秋田機関区配属

昭和18年 5月10日 長町機関区
昭和21年12月13日 柳井機関区
昭和34年 3月21日 厚狭機関区
昭和47年12月 1日 用途廃止

記 昭和56年10月吉日
(平成27年3月石版を複製)

<資料> 殿町児童公園看板より

Message card

パンフレット・手紙などを入れる箱

M.Mihata

Not for sale
売り物ではない

提供：観光ボランティア「おいでませ山口桜NAVI