

Not for sale
売り物ではない



option



option

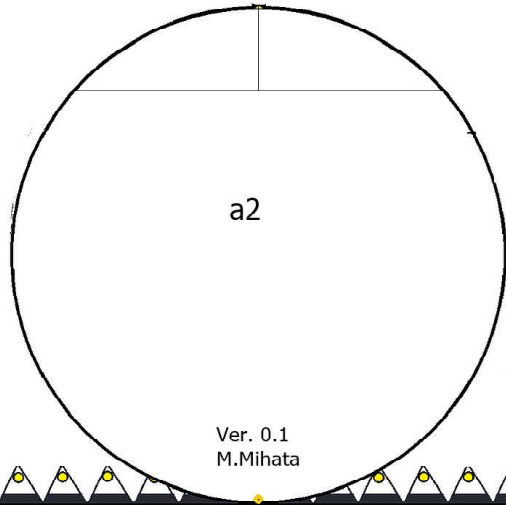

Ver. 0.1
M.Mihata

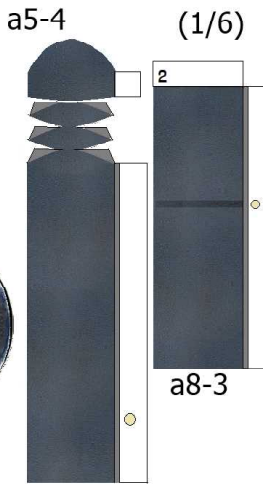
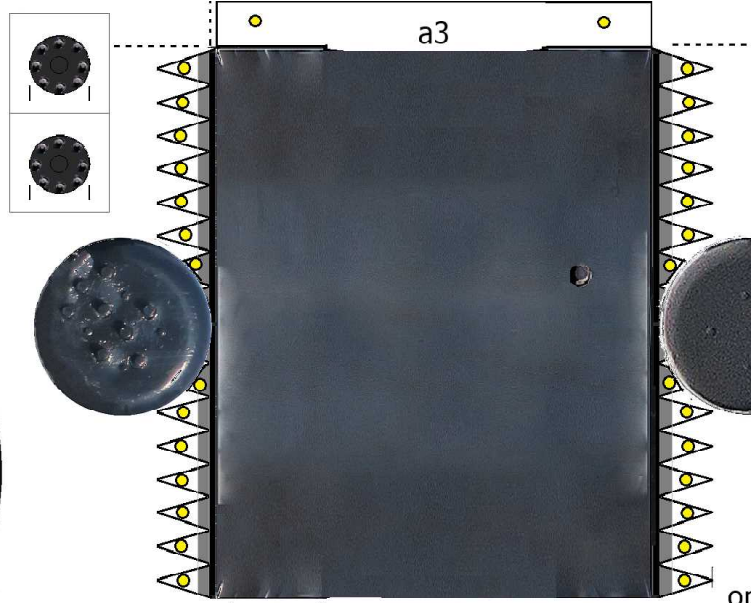

(1/6)

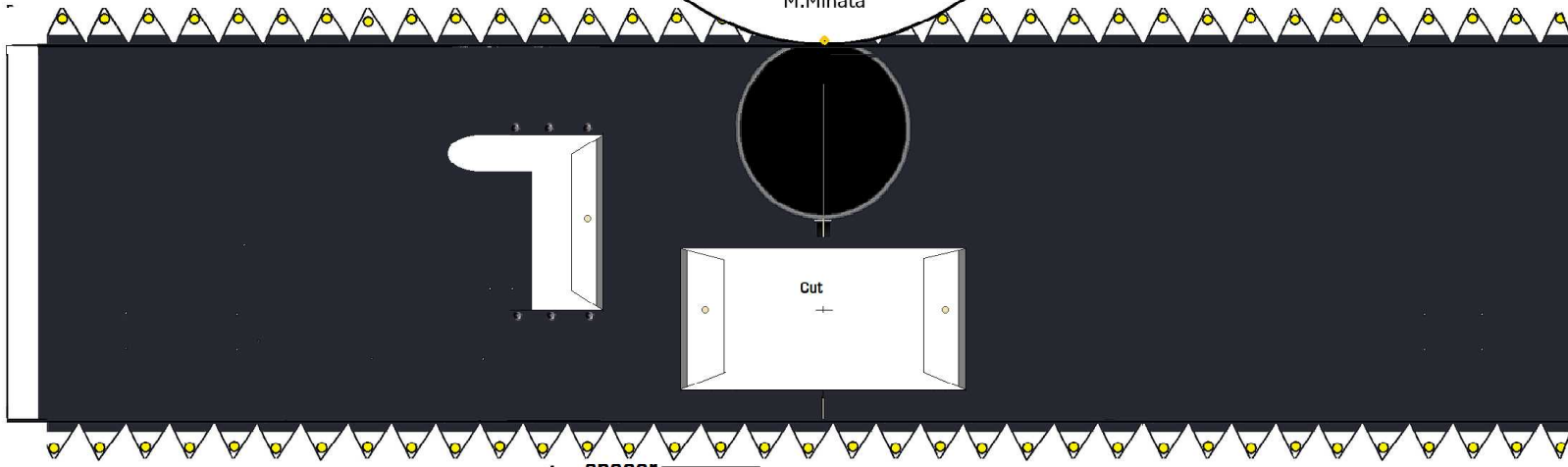

Cut

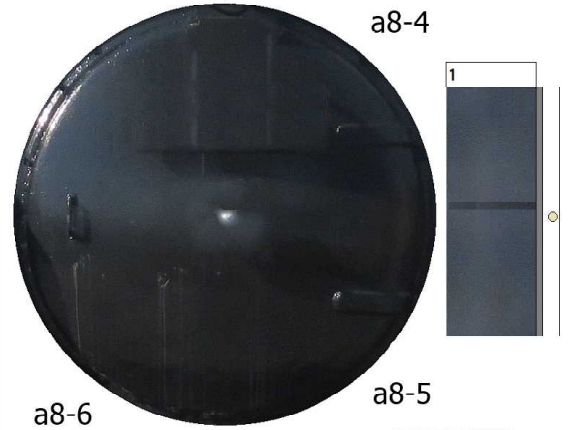

a8-4

a8-6

a8-5



a4 spacer

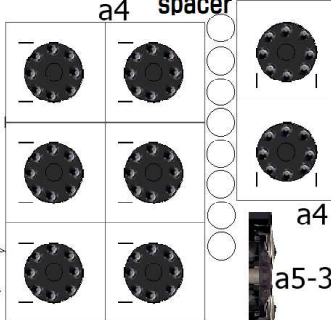

a3-1

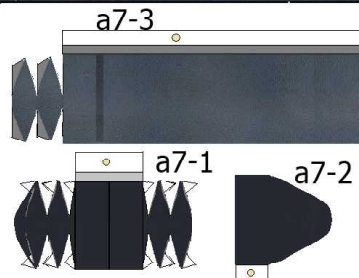

a7-3

a7-1

a7-2



a8-1

option

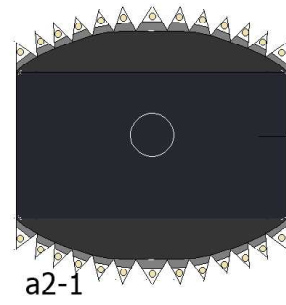

a2-1

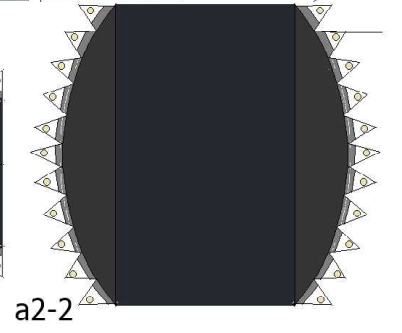

a2-2

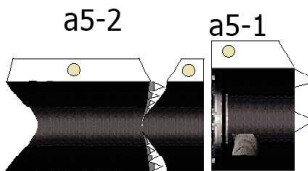

a5-2

a5-1

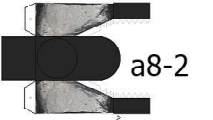

a8-2

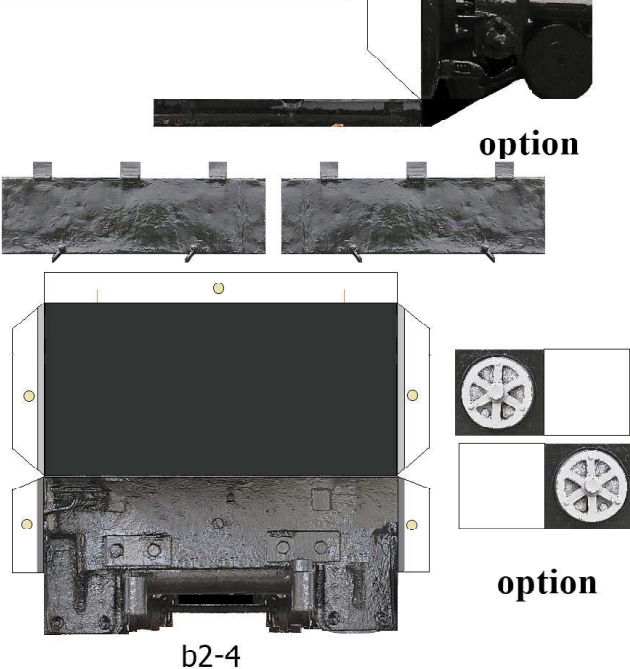
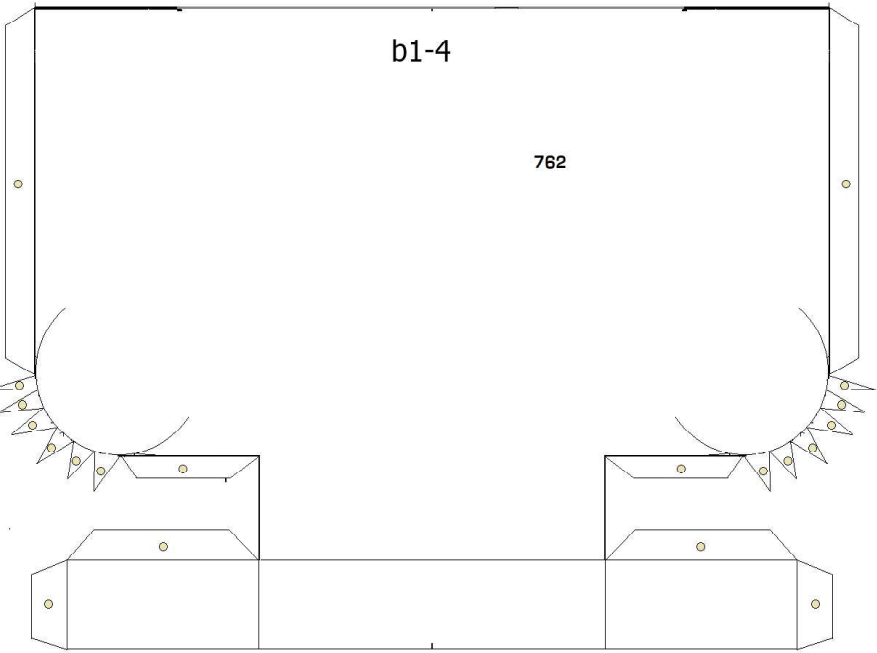
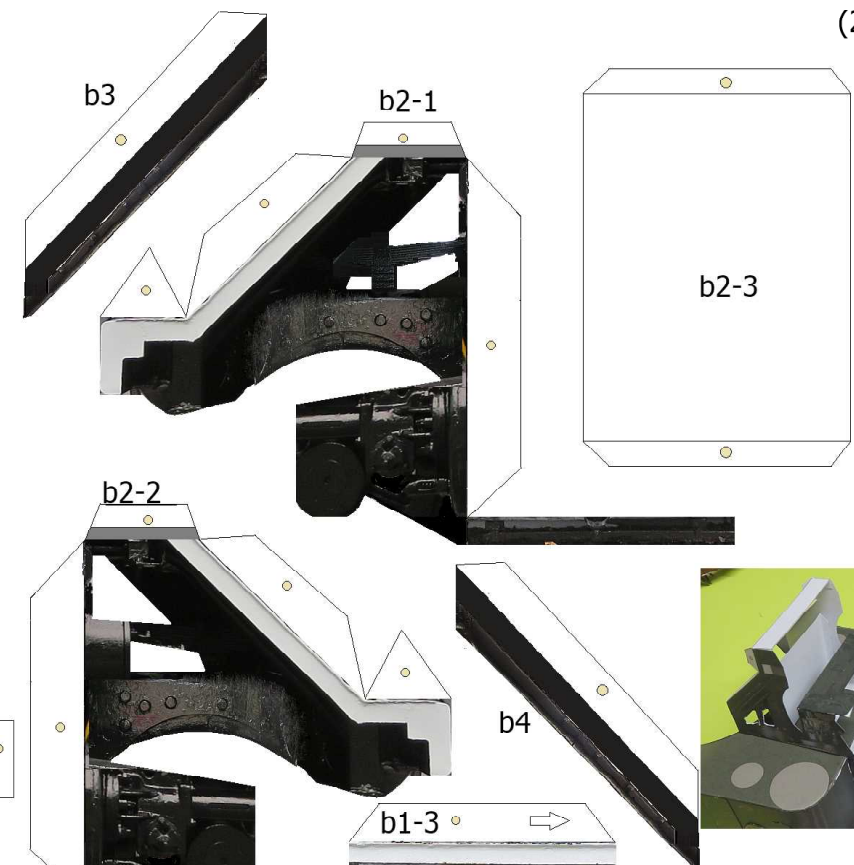
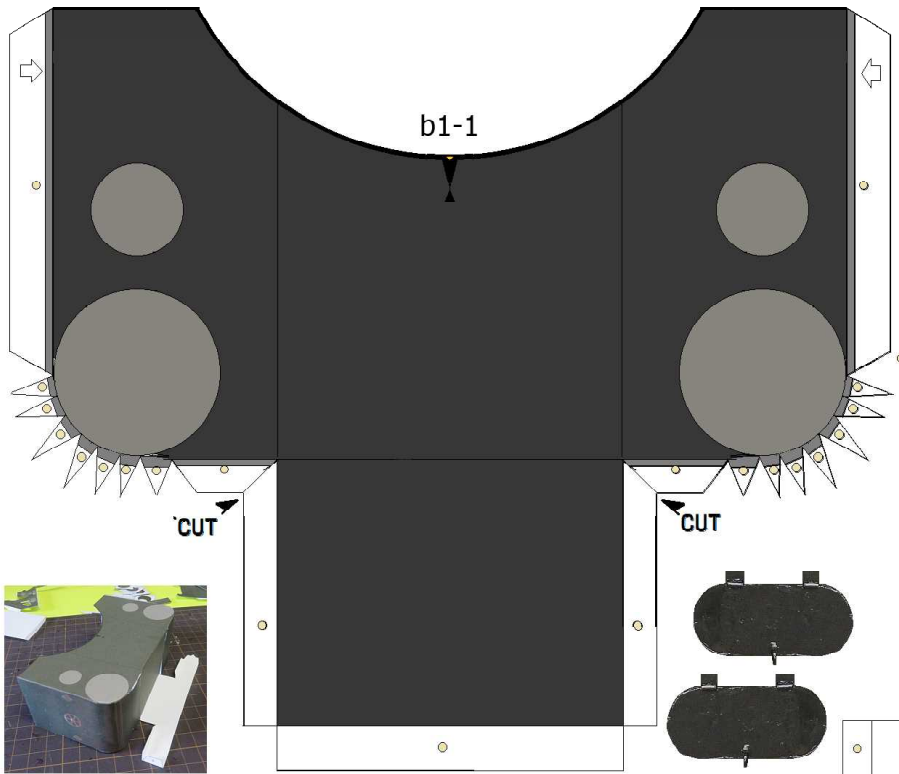

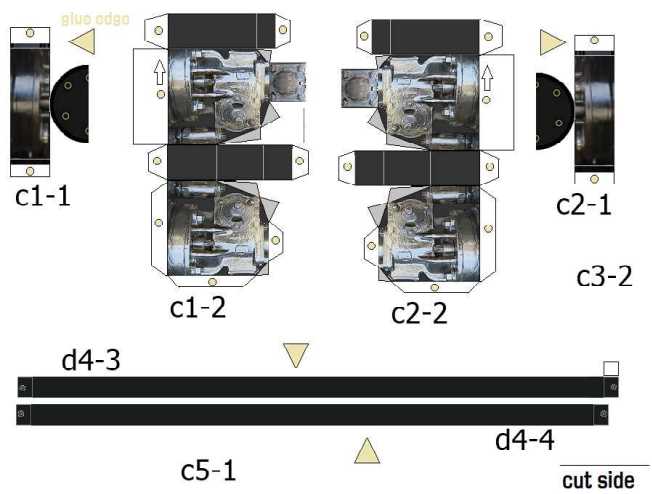

のりしろのない部分は
エッジ(断面)にボンド

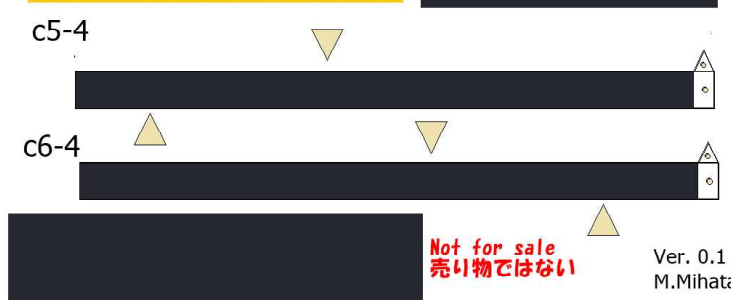
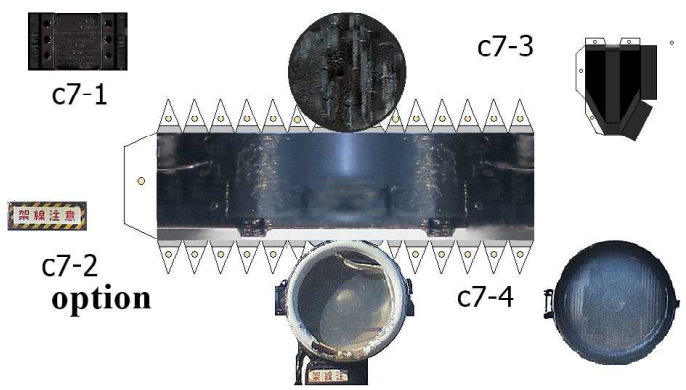
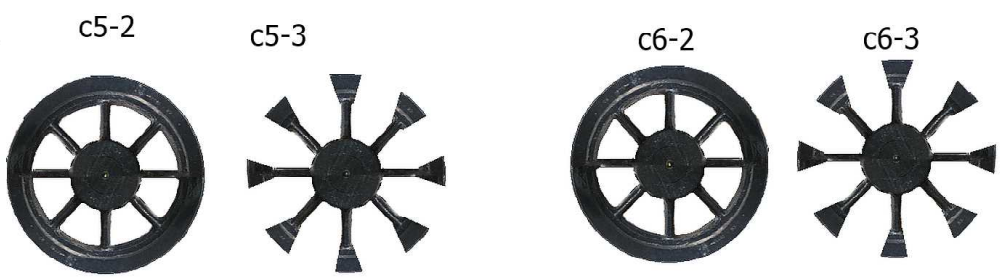
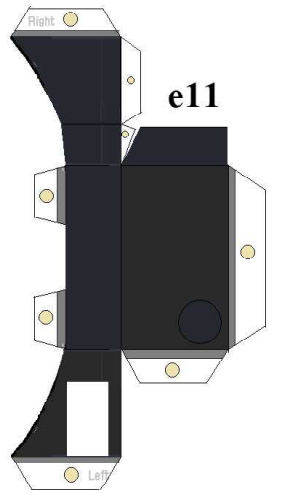
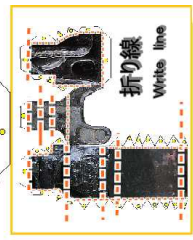
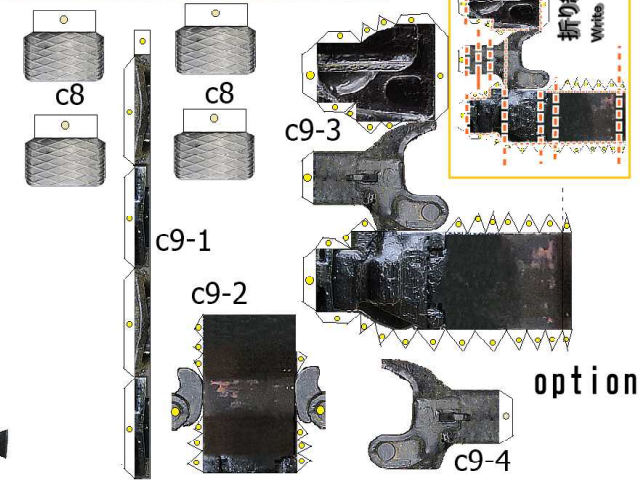
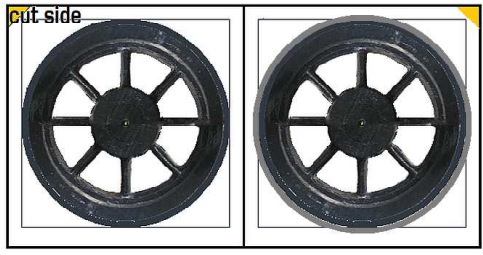
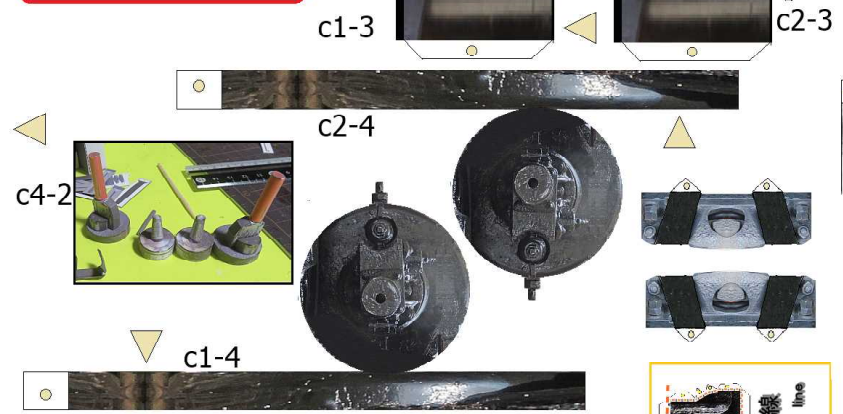

Not for sale
売り物ではない

ア-14-3576・147654-11-V



提供：観光ボランティア「おいでませ山口桜NAVI

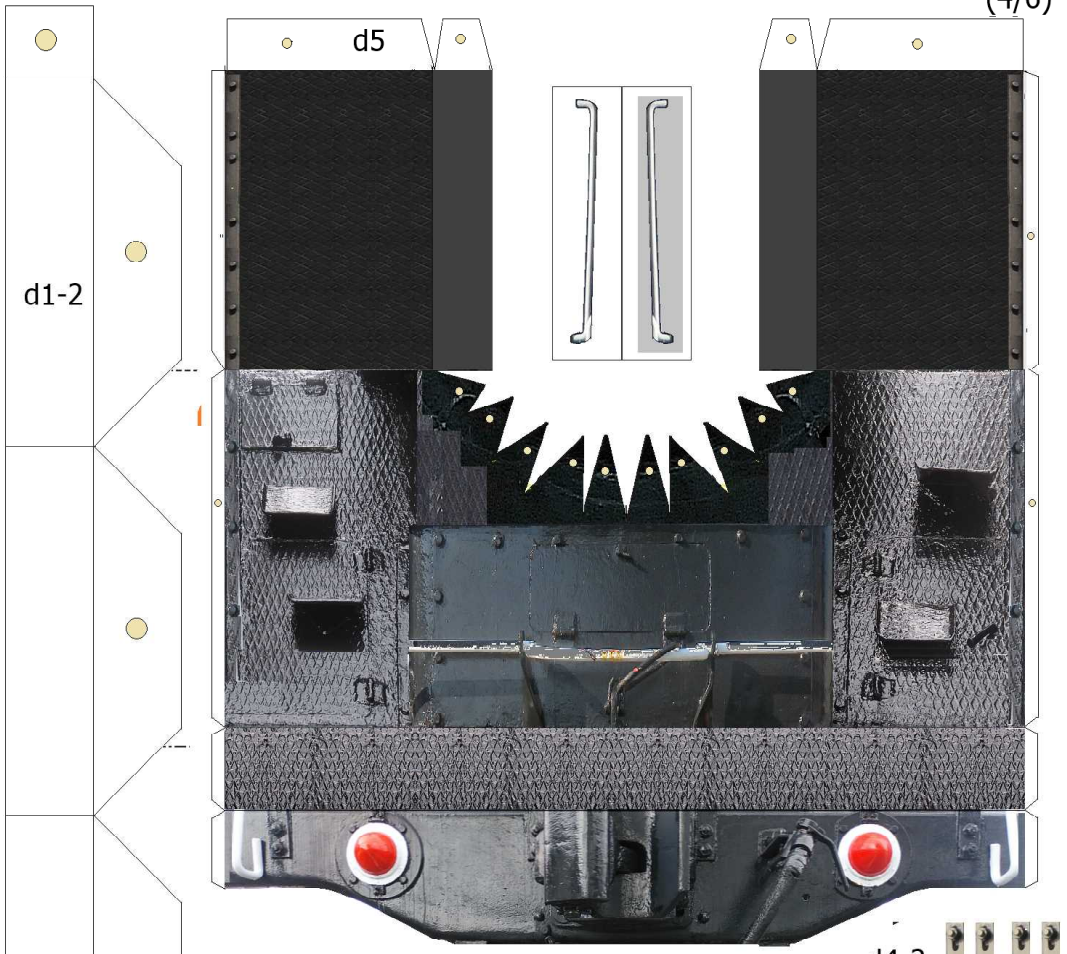
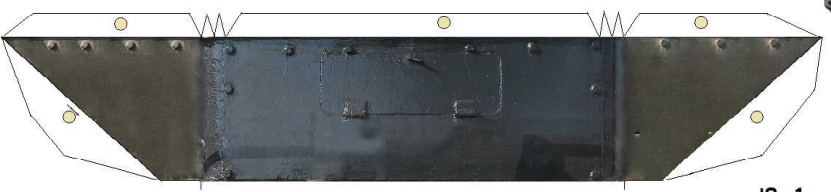
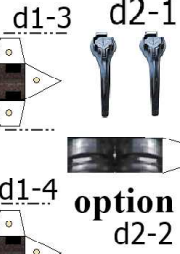
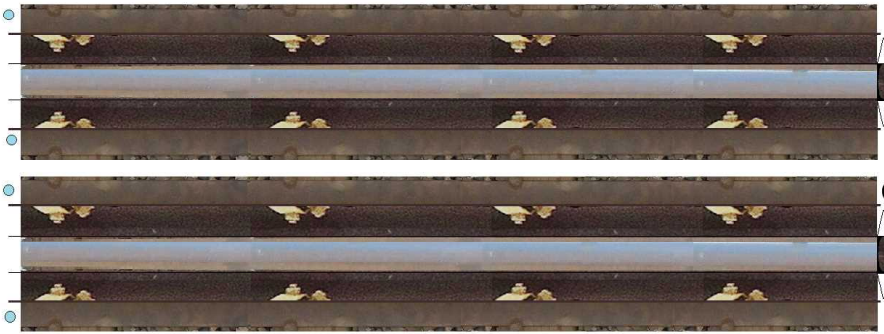

Not for sale
売り物ではない
Ver. 0.1
M.Mihata

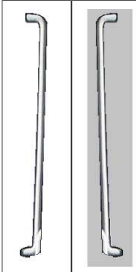
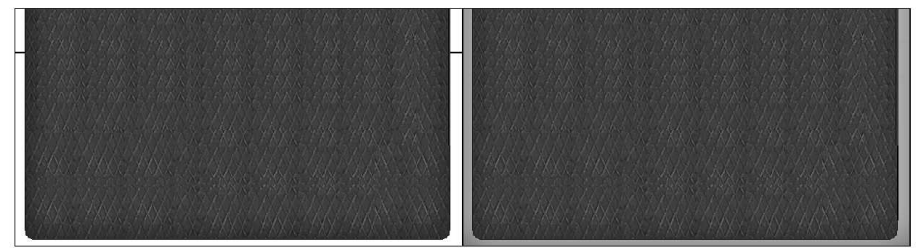

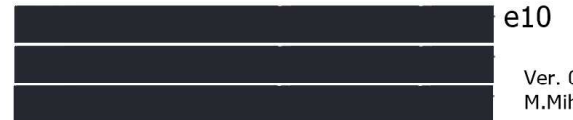
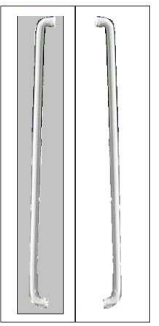
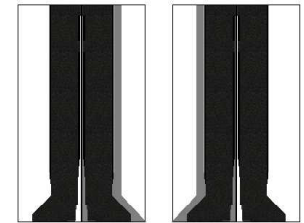
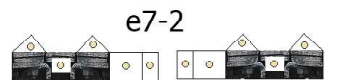
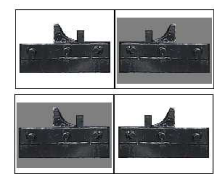
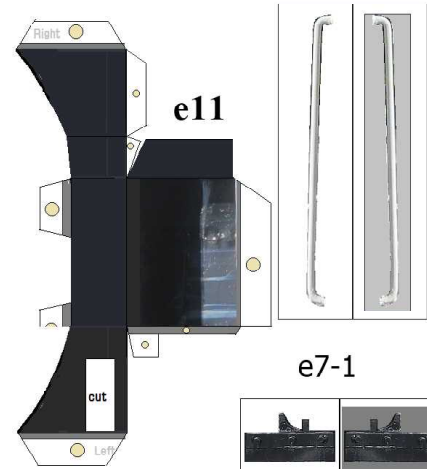
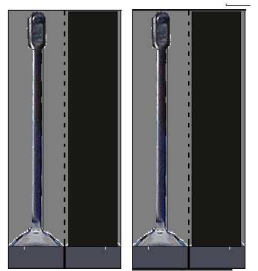
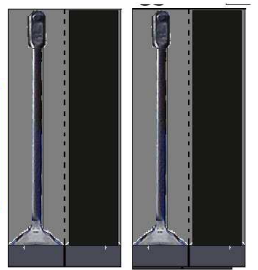
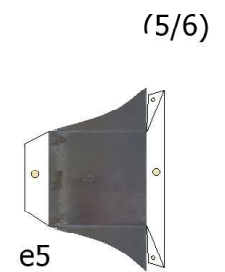
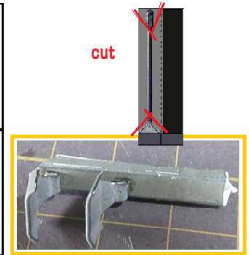
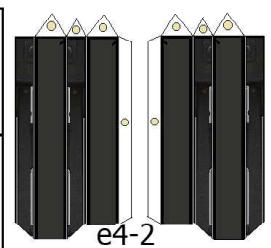
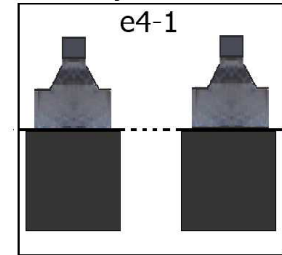
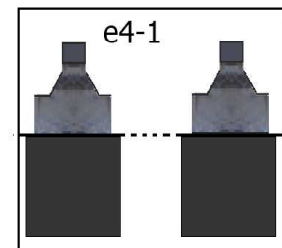
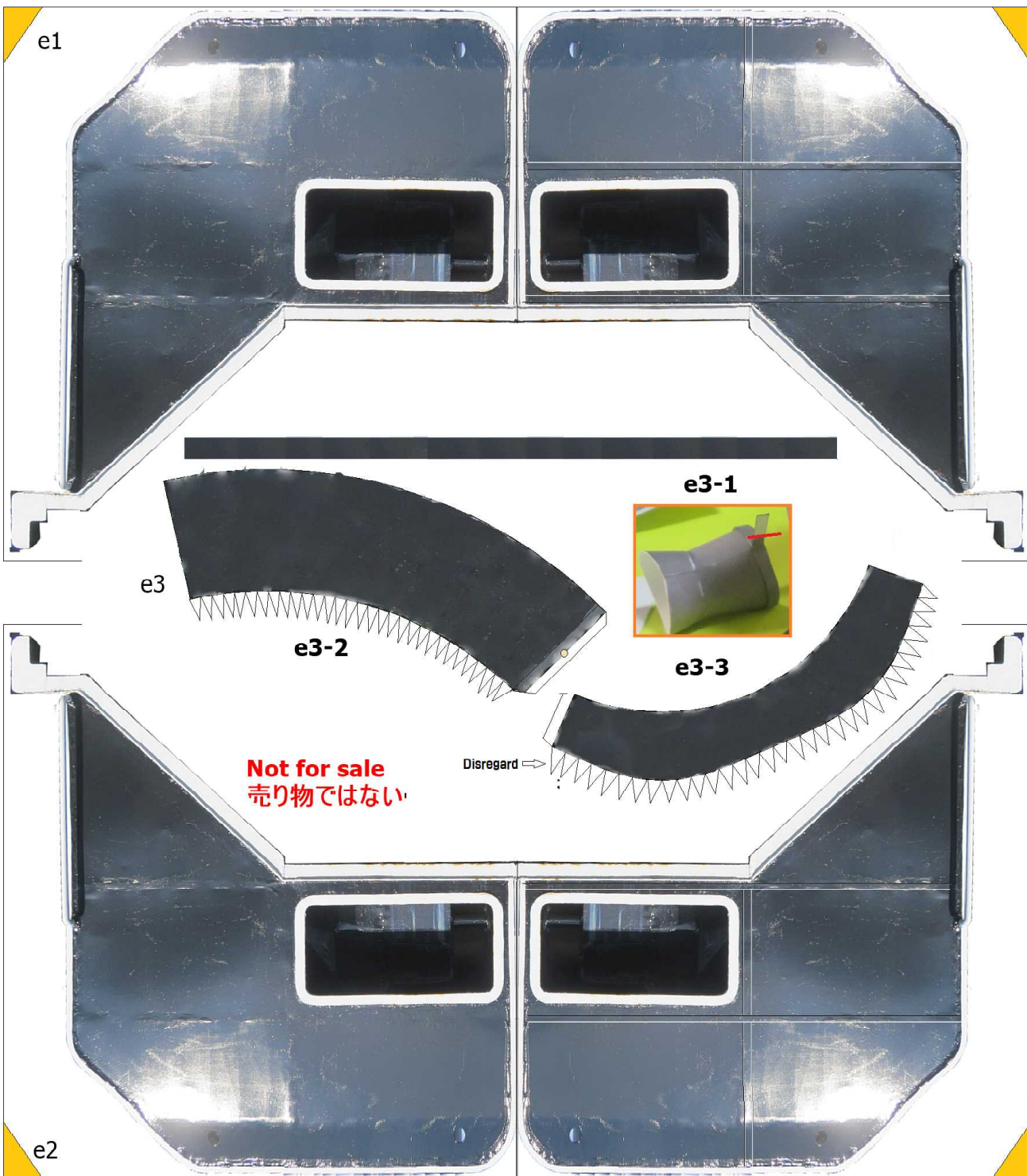

f1

f2

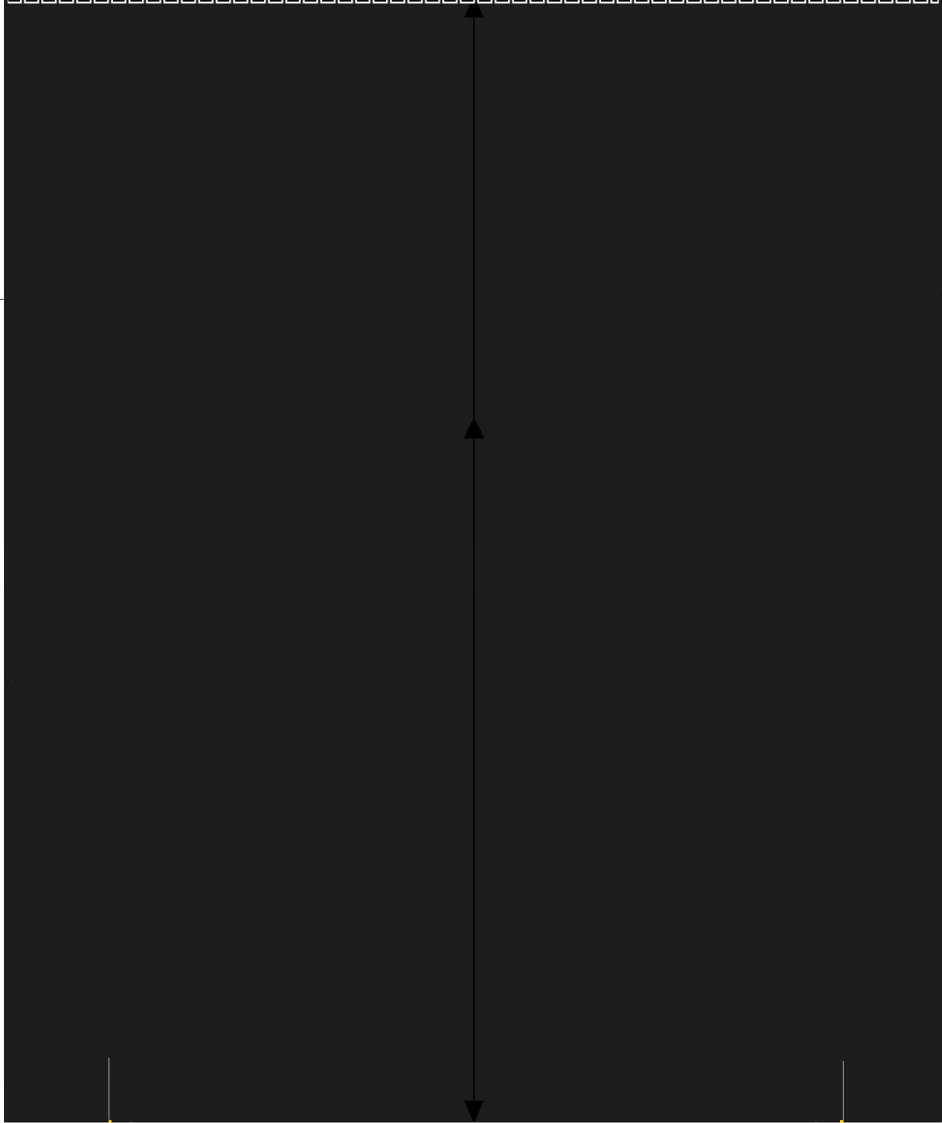

Message card

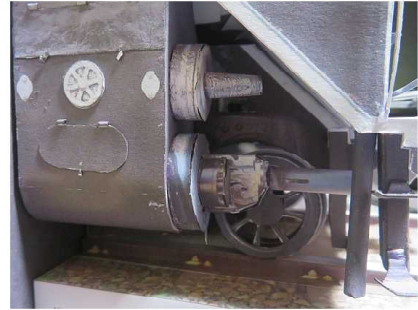

D51型蒸気機関車について
 D51型蒸気機関車は昭和11年から造られ旅客、貨物の輸送に活躍し「テコイチ」の愛称で呼ばれている日本の代表的な機関車です。
 このD51813蒸気機関車は昭和18年9月30日に誕生し約145万キロ橋って日本各線で活躍しました。昭和30年代以降、動力の近代化が進むようになり蒸気機関車がだんだん姿を消すようになり昭和50年3月に役目を終了しました。昭和50年11月に旧小郡町ではこの由緒ある蒸気機関車を当時の日本国有鉄道から借り受けここに展示しました。
 令和2年3月
 山口市

昭和18年9月30日 三菱三原車両製作所製造
 昭和18年11月1日 山陽本線 岡山機関区
 昭和21年11月29日 山陽本線 下関機関区
 昭和47年 21日 山陽本線 小郡機関区
 最大 全長 19.73メートル
 幅 2.78メートル
 高さ 3.98メートル
 最大けん引力 1100トン
 最大出力 1575馬力
 最大速度 時速75キロメートル
 走行距離 1459402キロメートル



パンフレット・手紙などを入れる箱

M.Mihata

Not for sale
売り物ではない

提供：観光ボランティア「おいでませ山口桜NAVI

普通紙印刷用 パイプ状にする時に使用

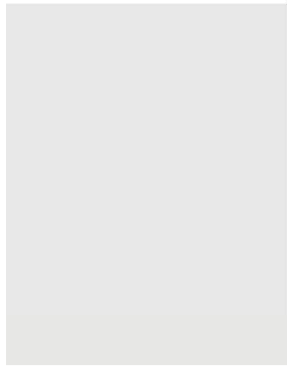
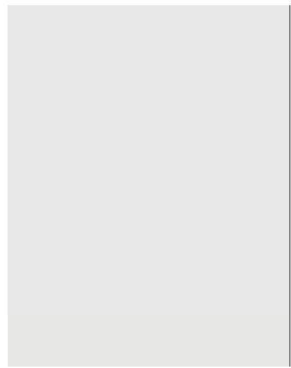
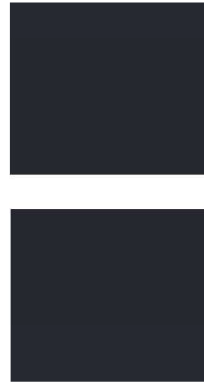
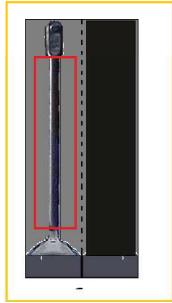

a5-4

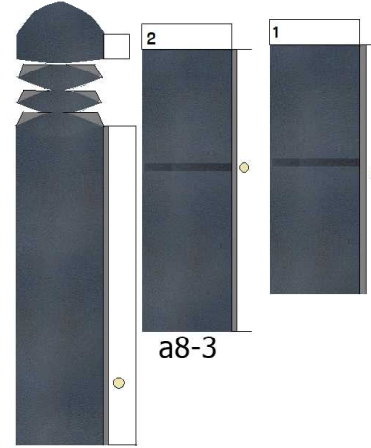

a7-3

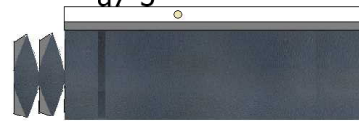

a8-6

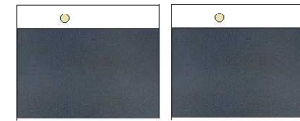

a7-1

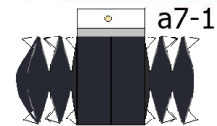

a7-2



a5-2

a5-1

